

# Gerber Drag Conveyor OPTIONAL FEATURES

**RAPAT**  
CORPORATION



#### ■ DISCHARGE GATES -

Single or multiple locations for versatility. Unique carry bars keep chain from dropping into gate, and allow gate to operate— even when conveyor is not running. Manual, electric or pneumatic operation available to fit your specific use.

#### ■ SPLIT SPROCKETS -

Allow easier maintenance without drive system tear down.

#### ■ BYPASS INLETS -

Material bypasses top flights and is directed to the bottom flights along both sides of conveyor for smoother material handling.

#### ■ BEND SECTION -

Designed for installations that require a slight incline or decline along conveyor route.

#### ■ EXTENDED WEAR OPTIONS -

Heavier steel frames, chains, paddles and drive systems are available. Please contact your Rapat representative for your specific use requirements. All Rapat systems are designed specifically for their intended use, so you can be assured of trouble-free performance.

#### ■ REVERSING -

Allows conveyor to run in both directions.

#### ■ LINERS -

Abrasion resistant steel liners are recommended.

#### ■ PLUG SWITCH

Stops conveyor operation if material clogs conveyor. (Shown below).



## GERBER DRAG CONVEYOR

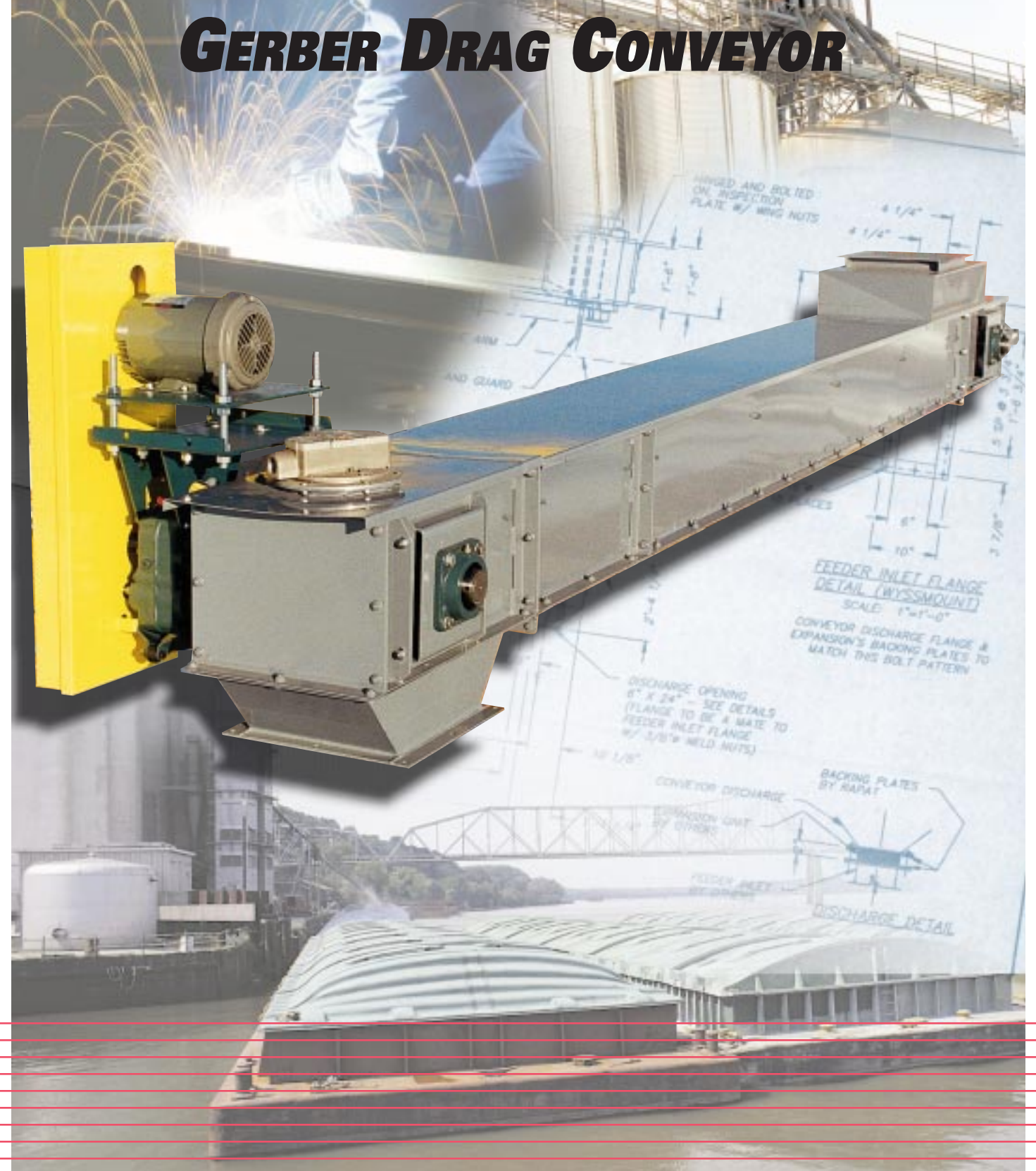

## RAPAT CORPORATION PRODUCT LINE CARD

#### CONVEYORS

- ENCLOSED BELT
- BAGGING
- CLEATED BELT
- TRUCK & RAILCAR UNLOADERS
- FLEXIBLE SIDEWALL
- PORTABLE BELT
- FOOD HANDLING
- TROUGHING ROLLER
- PLASTIC & WIRE BELTS
- SLIDER BED
- STAINLESS STEEL CONSTRUCTION
- EN-MASSE (DRAG)
- CUSTOM CONVEYORS

#### DISTRIBUTORS

- ROTO-FLO
- ROTARY VALVE
- SWING FLO

#### BUCKET ELEVATORS

- COMPLETE BUCKET ELEVATOR ASSEMBLIES
- CUSTOM ACCESSORIES
- BACKLEG ROLL OPTIONS

#### SCREW CONVEYORS

- TUBE TYPE SCREW CONVEYORS
- AUGER FLIGHTING

#### HORIZONTAL UNLOAD POWERHEADS

- 25 DEGREE INCLINE POWERHEADS
- BIN UNLOAD TUBES WITH ROLLER SLIDE GATES
- BANJO SUMP BIN UNLOAD TUBES
- ELECTRIC / HYDRAULIC DRIVE KITS

#### ACCESSORIES

- HOPPER CAR UNLOADERS
- TRANSFER SPOUTING
- CAST IRON TURNHEADS
- REVERSIBLE ELBOWS
- DRAW OFF SPOUTS

#### INDUSTRIAL MATERIAL HANDLING SOLUTIONS THAT WORK!

At The Rapat Corporation, we approach each project with the intent of finding a better way to solve our customers problems by listening to their individual needs, and applying what we learn to best solve their specific material handling requirements.

Put our experience with some of the largest Fortune 500 Corporations to work for you— call toll-free today for more information.

669 WHITEROCK ROAD, BATHURST, NSW, 2795 AUSTRALIA,  
PHONE> +61 (0) 438322788  
EMAIL> [mark@avimain.com.au](mailto:mark@avimain.com.au)  
WEB> [avimain.com](http://avimain.com)

# Gerber Drag Conveyor FEATURES

## FEATURE FOR FEATURE, THE BEST DRAG CONVEYOR ON THE MARKET

The Drag Conveyor is a product designed for the real-world—engineered to handle the stress and demands of your material handling needs.

Quiet operation is a trademark of the Drag Conveyor. Specially placed UHMW slide rails, along with carefully selected chain and sprocket assemblies make it operate smoothly and quietly. Easy field upgradability is built into every unit, ensuring years of usability.

One of the first things our customers' notice is how well the product assembles. That's no accident! It's the result of a carefully engineered and manufactured product that is designed to very exact tolerances. These tolerances are measured, and re-measured during every stage of manufacturing to make the Drag Conveyor one of the easiest purchase decisions your company will make this year.

## UNIQUE FLIGHT DESIGN

Rapat's unique flight design uses replaceable UHMW wear bars on standard steel conveyors or units with abrasion resistant steel bottoms.



The formed acute angle flight design provides maximum strength and assures proper end cleanout when intermittent discharges are used. This feature is standard on all Drag Conveyors.

## JIG WELDED FRAME

Our frame system is jig welded—making it straight and true. Construction is of 12 gauge mild steel with optional Abrasion Resistant liners.

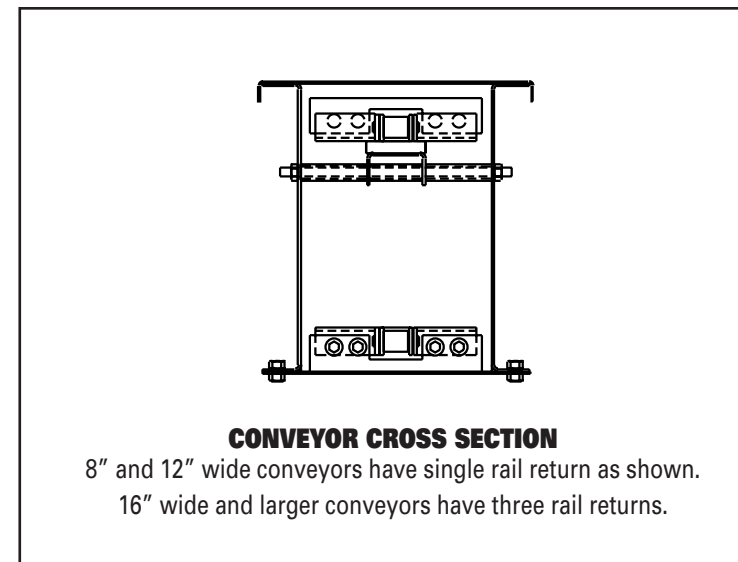
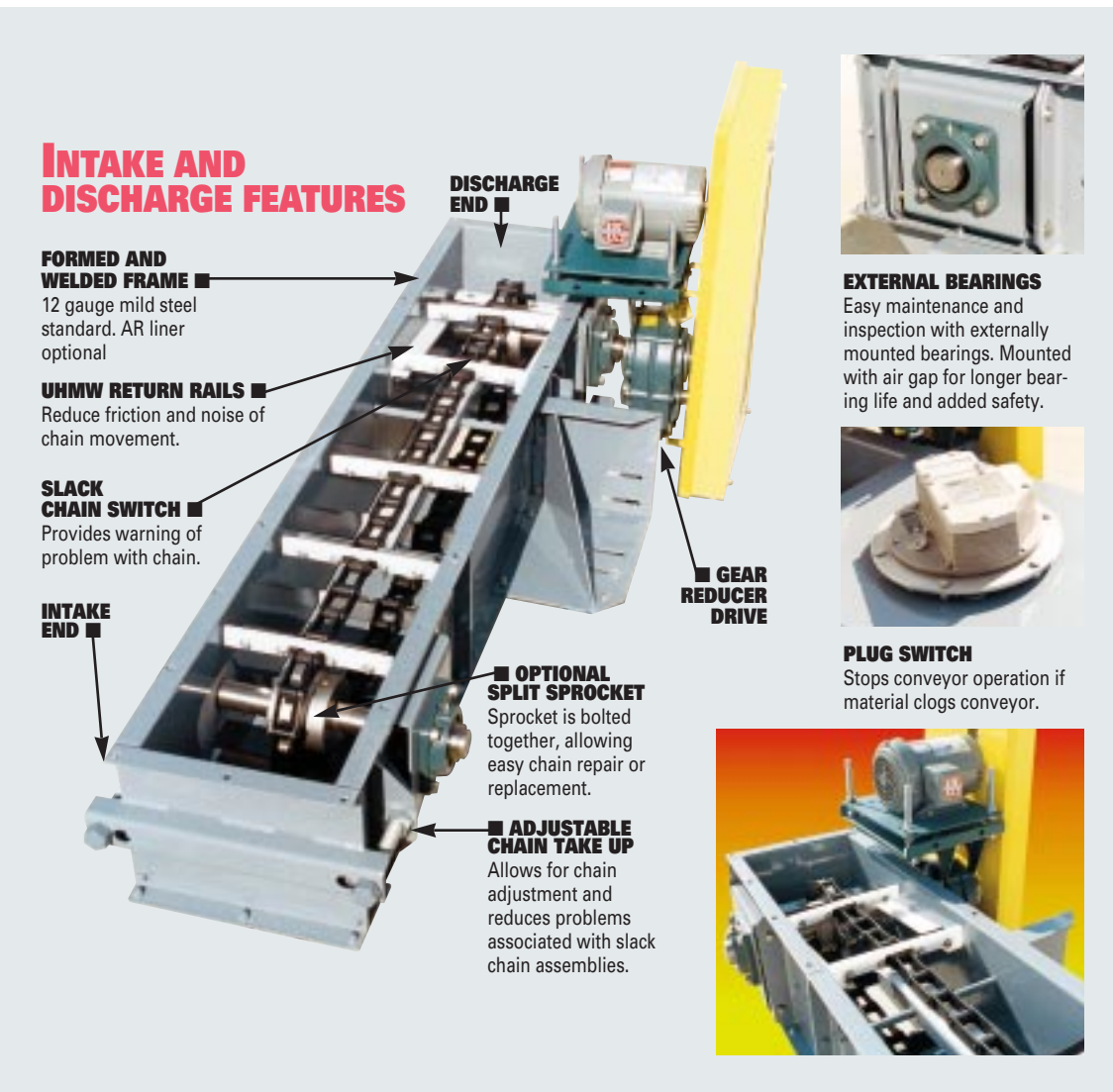
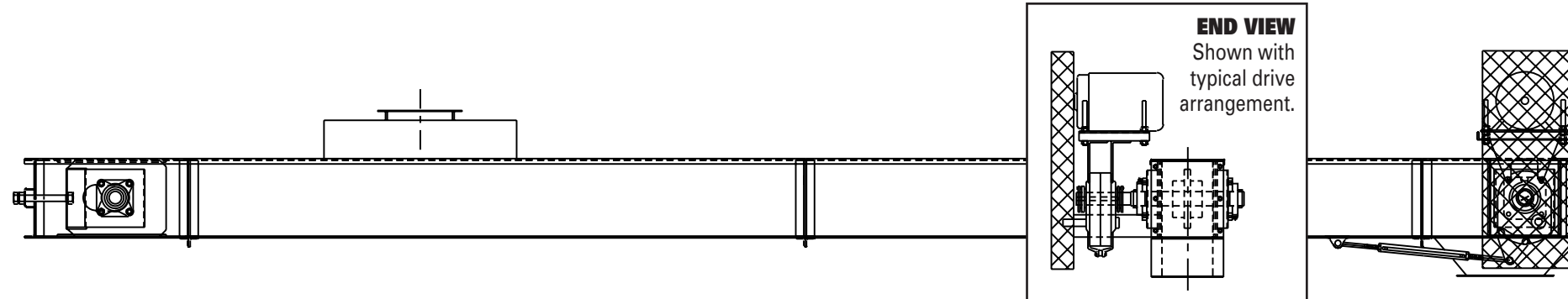

## MATCHED CHAIN AND SPROCKET SYSTEMS

Rapat carefully selects the chains and sprockets, allowing easy change in the field should the conveyor require repair or upgrade after initial installation.

## EASY ACCESS FOR MORE REGULAR MAINTENANCE

Most parts requiring regular maintenance are externally mounted for easy access. The drive system, bearings and other parts are all located for fast access.

Internal parts are quickly accessed by removable covers with screw-type clamping system (standard).

## SPECIFICATIONS

<b>Lengths</b>	All conveyors are custom made to fit your needs.
<b>Chain</b>	Standard and optional chains feature extra rigid formed and welded steel paddles with UHMW wear bars.
<b>Drive</b>	Shaft mounted gear reducer with V-belt or HTD belts. Direct motor gear box drive (with no belts or pulleys) also available at additional cost.
<b>Frame</b>	Formed and welded 12 gauge mild steel trough with optional AR liner.
<b>Power</b>	Three phase electric motors recommended (not supplied). Units come with shaft extended on right hand side standard. Other mounting location options are available.
<b>Sprockets</b>	Solid steel sprockets standard, split sprockets are available as option.
<b>Plug Switch</b>	Stops conveyor operation when material clogs conveyor.
<b>Slack Chain Switch</b>	Indicates when a slack chain occurs, due to breakage, wear or other chain-related problem.
<b>Return Rails</b>	All return rails are lined with UHMW for smoother, quieter operation.
<b>Cover Clamps</b>	Screw clamps hold cover in place, allowing easy access for inspection or repair. Other clamp systems are available as options.

All specifications subject to change without notice.

**RAPAT**  
CORPORATION